



Microsoft Upstream Reference Architecture Initiative



Paul Nguyen, Microsoft Corporation
OpenSpirit Technical Symposium
Houston – September 2010



Microsoft in Oil & Gas (Overview)



- US based Oil & Gas Industry team established in 2002
- A truly global approach since 2007
- One of the fastest growing Industries for Microsoft, in more than 70 countries
- 10+ GTM Global Alliance Partners for 2011
- 180+ Oil & Gas Account Managers
- 500+ partners in the O&G partner catalogue
- 600+ members of the Microsoft internal Oil & Gas community

Current Market Situation

- Variation in application infrastructure leads to added complexity in IT infrastructure to support applications
- Lack of common application foundation services reduce the opportunity for seamless interoperability between applications/components
- Production and drilling applications are moving more and more from shrink wrapped apps to enterprise apps composing of portal, DB, collaboration, knowledge management and sharing, business intelligence, etc...
- The cost of interoperability is high for owner operators, and also normally constrained by proprietary interfaces and architecture
- Customers continue to demand open architecture and better interoperable solutions from vendors

Upstream Oil & Gas Computing Trends Survey 2010

64% - See high value in a simpler and more unified upstream computing environment in term of job performance

Data Access and Accuracy Rank High as Benefits

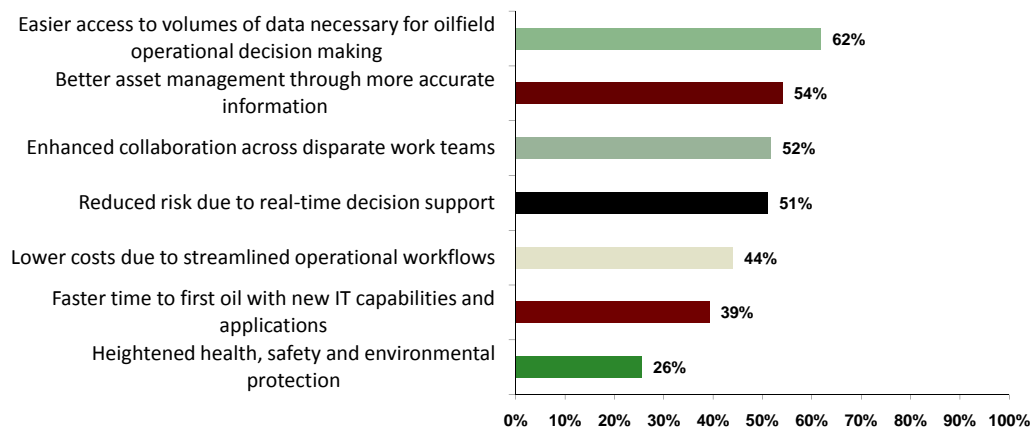

Q. - What are the top benefits you would expect from a simpler and more unified upstream computing environment? (Select your top three responses)

More Say Industry-Wide Collaboration Can Provide this Computing Environment

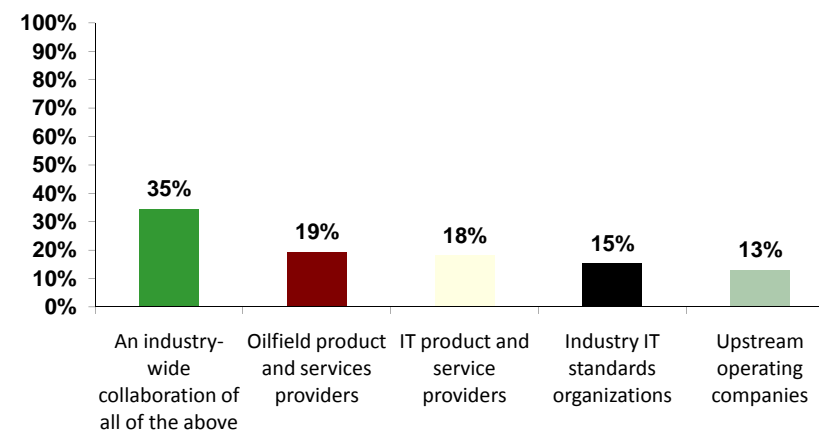

Q. - Who do you see as most capable of creating a simpler and more unified computing environment across the upstream oil and gas sector?

Upstream Oil & Gas Computing Trends Survey 2010



Professionals Optimistic about New IT Standards and Technologies for Efficient Computing...

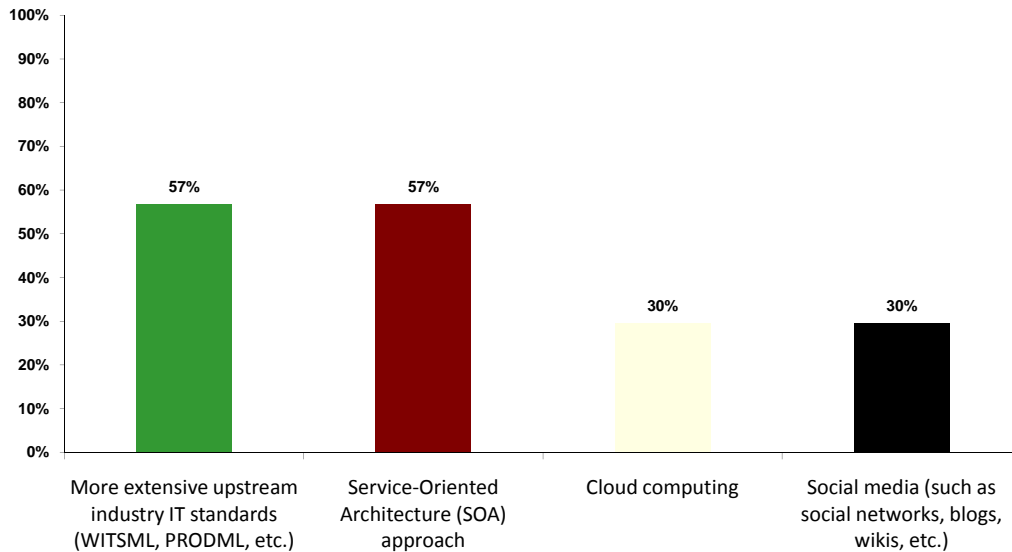

Q. - Which of the following do you see as promising for helping create a simpler and more unified upstream IT environment? (Select all that apply)

...But Company Adoption Lags Behind Interest

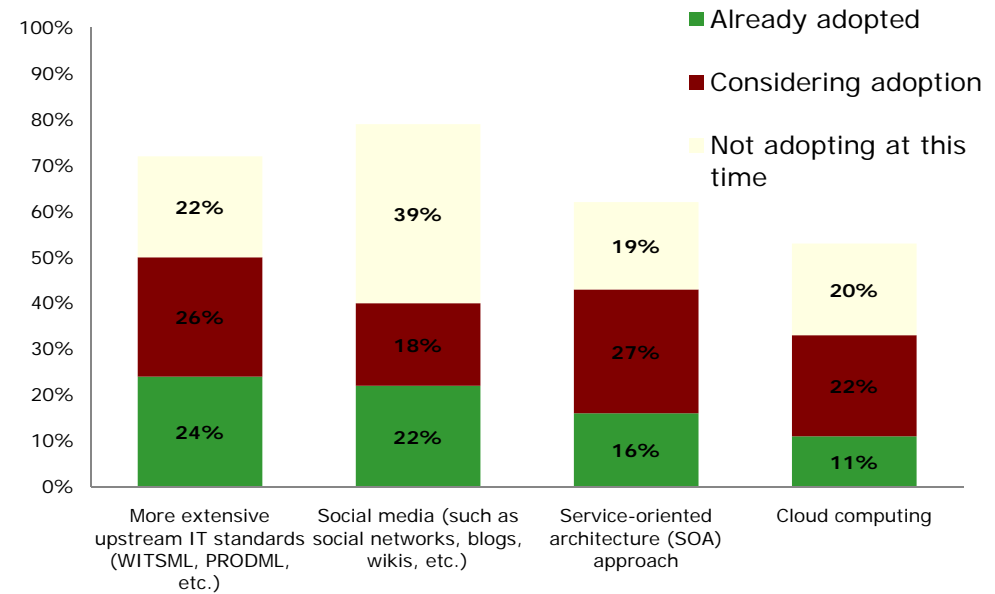

Q. - How seriously is your company pursuing adoption of the following?

The Microsoft Upstream Reference Architecture Initiative



A coherent reference architecture that enable better integration amongst upstream applications through the composition of common application components

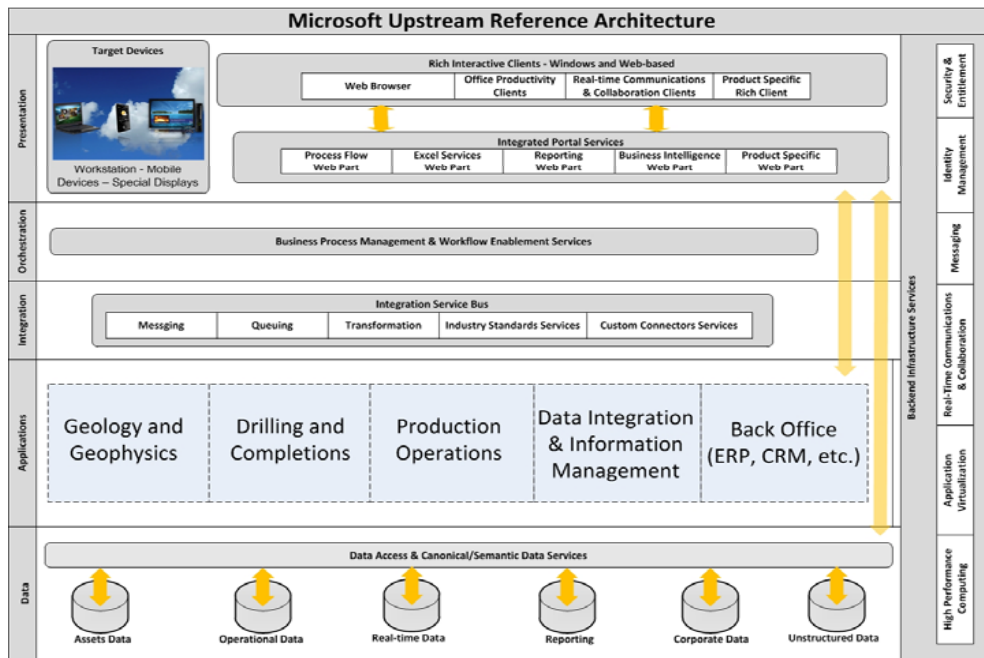

Oil and Gas Reference Architecture's Foundational Principles

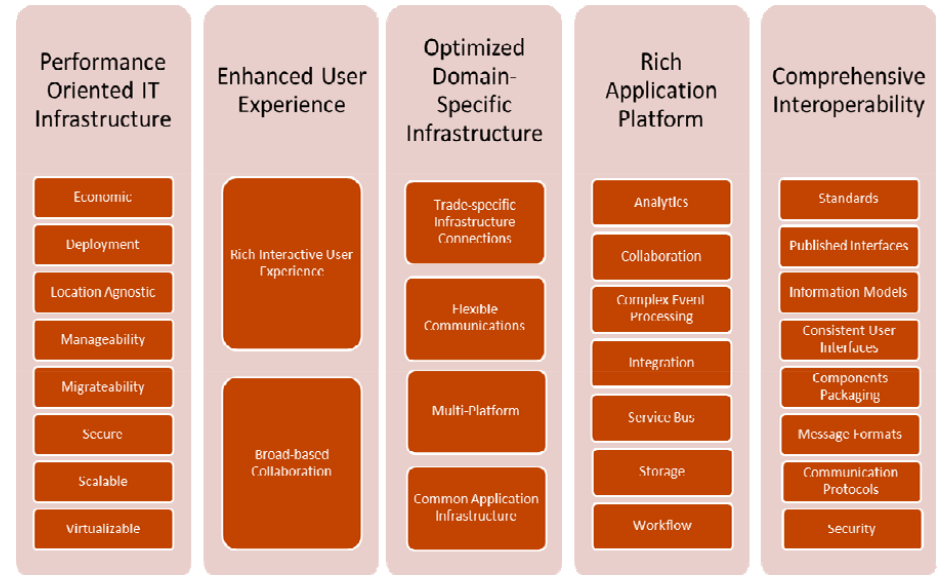

Dual-Approach to Reference Architecture



Top-Down Business-Application-Infrastructure (Example)

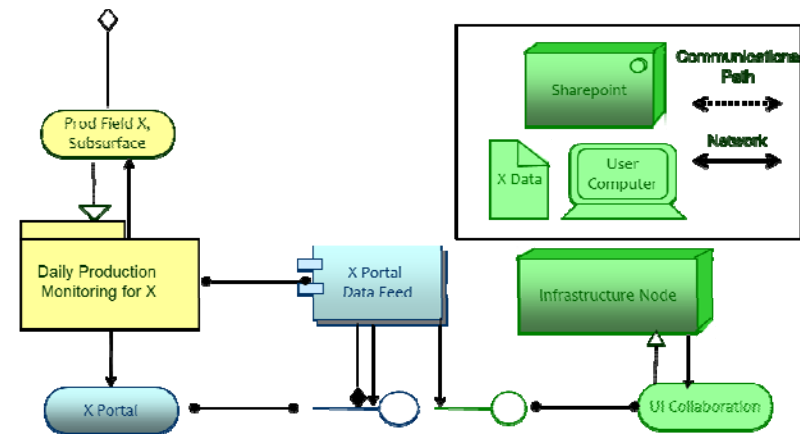
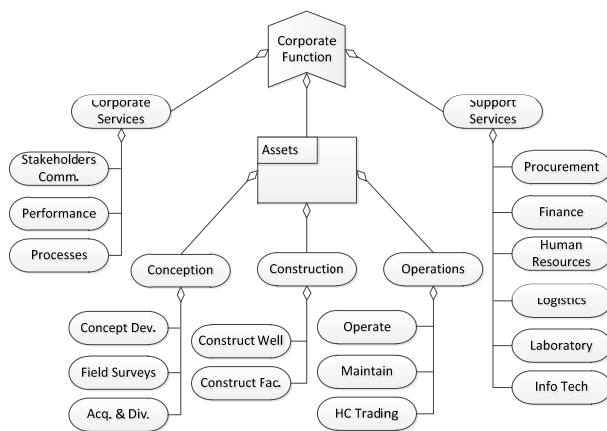

Interoperability Demo

Microsoft®

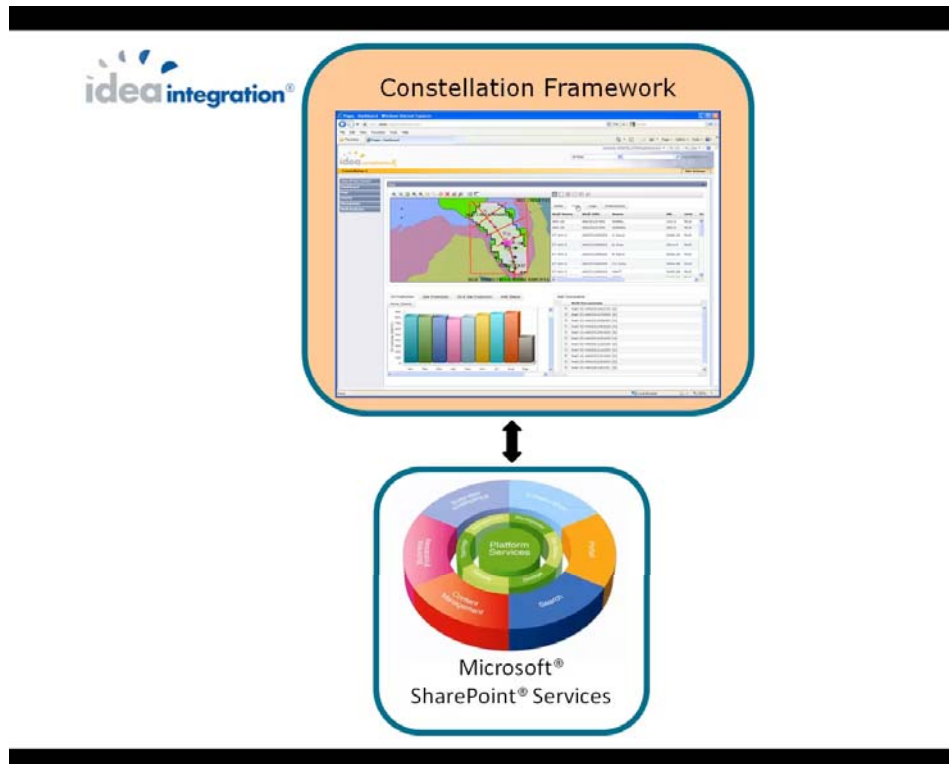

MURA Initiative Benefits

- **Customers:**

- Ability to influence and drive convergence on vendor approaches on solution delivery
- Drive down the TCO of adopting 3rd party and internally built solutions within the customer's environment
- Ability to pick and chose best of breeds solution available in the market
- Enable cross-domain collaboration/workflow
- Enable inter-organizational collaboration on common infrastructure

- **Solution Providers:**

- Improve standing and reputation with customers as a vendor delivering solutions that are open and utilize mainstream architectures
- Built-in compliance to customer enterprise and/or industry de-facto standards
- Enable vendor to differentiate by focusing investment in domain expertise and IPs versus underlying application infrastructure

Resources



- White Papers
 - [Vision for an Upstream Reference Architecture](#)
 - [The Road to an Upstream Reference Architecture](#)
- Microsoft Upstream Reference Architecture Initiative home page - <http://www.microsoft.com/industry/manufacturing/oilandgas/solutions/mura.msp>



Microsoft®

Paul Nguyen
Paul.Nguyen@microsoft.com
+1 425 538 1449



OpenSpirit **right**
from the **start**